

**Expanded Metal  
and Grating**



New Metals, Inc. is one of the largest producers of expanded metals in North America. Founded in 1954, New Metals, Inc. produces a complete line of quality expanded metals, expanded metal grating, ornamental metal parts and refuse baskets.

Shipments of most products are made from factory inventory and stocks maintained by Steel Service Centers located throughout the United States and Canada.

New Metals, Inc. also manufactures a wide variety of special products and provides many services, such as shearing, expanding to size, finishing and parts fabrication.



On April 12, 1996, New Metals, Inc. was awarded international recognition in the form of ISO 9002 Certification. The objective of the ISO 9002 Quality Assurance System is to provide products and services that continually meet or exceed customer requirements.



It is the policy of New Metals, Inc. to achieve the COMPLETE SATISFACTION of its customers by offering exceptional quality products and services at a competitive price.

**Standard Expanded Metal (SXM)**

Standard expanded metal is a finished product as it comes from the press after having been die cut and expanded. Illustration shows that the strands and bonds form a sharp angle to the original plane of the solid sheet. Many times standard expanded metal is referred to as raised.

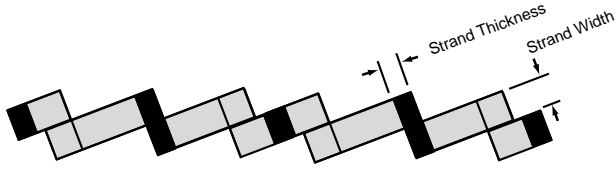

Pattern shown is actual size:

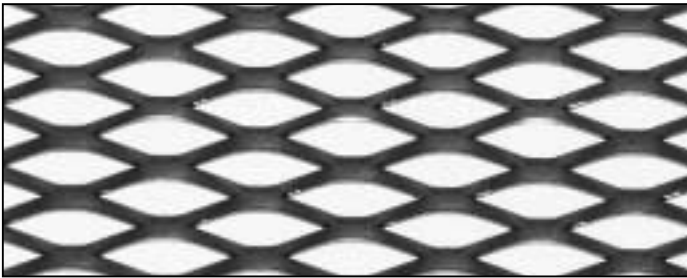

1/4" # 18 Standard

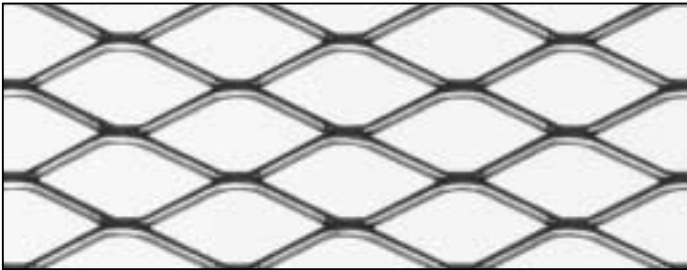

1/2" # 16 Standard

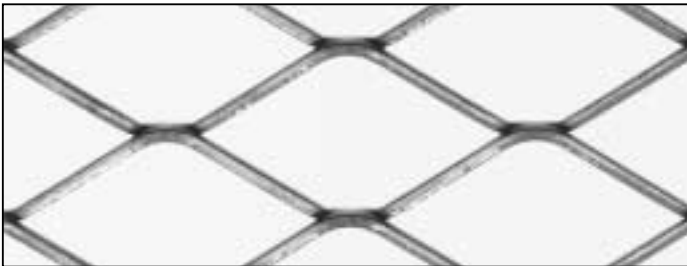

3/4" # 13 Standard



1-1/2" # 9 Standard

**Flattened Expanded Metal (FXM)**

Flattened expanded metal is standard expanded metal which has been cold rolled leaving a flat, smooth surface. Flattened expanded metal is about five percent lighter than standard expanded metal.

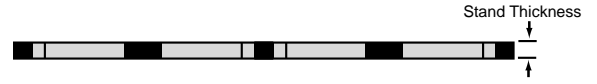

Pattern shown is actual size:

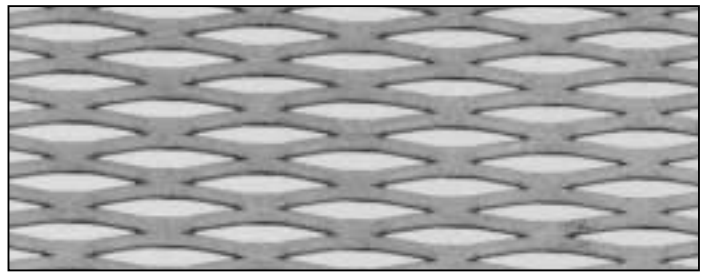

1/4" # 18 Flattened

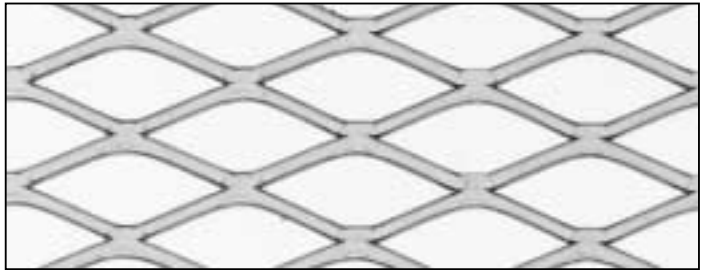

1/2" # 16 Flattened

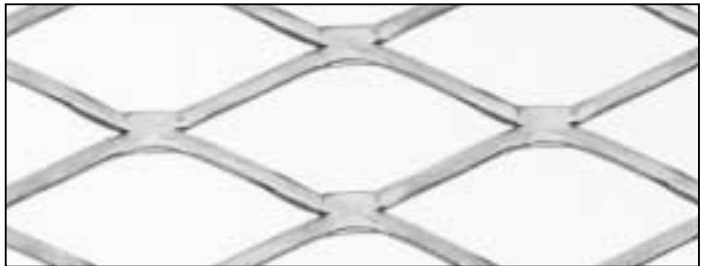

3/4" # 13 Flattened



1-1/2" # 9 Flattened

**Standard (Raised) Expanded Carbon Steel**

Style	Lbs. Per 100 Sq. Ft.	Standard Sheet Size (Feet)		Design Size Inches		Opening Size Inches		Approx. Strand Size (Inches)		Overall Thickness (In.)	Approx. No. Diamonds Per Ft.		% Open Area
		Width SWD	Length LWD	SWD	LWD	SWO	LWO	Thickness	Width		SWD	LWD	
1/4" # 20 SXM	86	4	8	.25	1.00	.17	.72	.036	.073	.125	48	12	45
1/4" # 18 SXM	114	4	8	.25	1.00	.17	.72	.048	.073	.125	48	12	43
1/2" # 20 SXM	43	4	8	.50	1.20	.44	.94	.036	.072	.124	24	10	80
1/2" # 18 SXM	70	4&6	8&10	.50	1.20	.44	.94	.048	.088	.155	24	10	77
1/2" # 16 SXM	86	4&6	8&10	.50	1.20	.38	.94	.060	.086	.157	24	10	71
1/2" # 13 SXM	147	4&6	8&10	.50	1.20	.31	.94	.092	.096	.182	24	10	58
3/4" # 16 SXM	54	4&6	8&10	.92	2.00	.81	1.75	.060	.099	.186	13	6	85
3/4" # 13 SXM	80	4&6	8&10	.92	2.00	.75	1.69	.092	.096	.195	13	6	78
3/4" # 10 (13 ga.) SXM	120	4&6	8&10	.92	2.00	.75	1.63	.092	.144	.282	13	6	77
3/4" # 9 (10 ga.) SXM	180	4,5&6	8,10&12	.92	2.00	.69	1.56	.134	.148	.300	13	6	66
1" # 16 SXM	44	4	8	1.09	2.40	1.00	2.06	.060	.096	.182	12	5	86
1-1/2" # 16 SXM	40	4	8	1.33	3.00	1.25	2.63	.060	.107	.211	9	4	89
1-1/2" # 13 SXM	60	4&6	8&10	1.33	3.00	1.19	2.50	.092	.104	.215	9	4	86
1-1/2" # 10 (13 ga.) SXM	79	4&6	8&10	1.33	3.00	1.19	2.50	.092	.137	.289	9	4	85
1-1/2" # 9 (10 ga.) SXM	120	4,5&6	8&10	1.33	3.00	1.13	2.38	.134	.142	.295	9	4	75
1-1/2" # 6 SXM	250	4&6	8	1.33	3.00	1.00	2.31	.198	.201	.425	9	4	63
2" # 10 (13 ga.) SXM	68	4	8	1.85	4.00	1.63	3.44	.092	.164	.312	6.5	3	86
2" # 9 (10 ga.) SXM	90	4	8	1.85	4.00	1.56	3.38	.134	.149	.325	6.5	3	86

**Standard (Raised) Expanded Stainless Steel**

1/2" # 18 SXM	73	4	8	.50	1.20	.43	.94	.050	.087	.164	24	10	77
1/2" # 16 SXM	91	4	8	.50	1.20	.43	.94	.062	.087	.164	24	10	70
1/2" # 13 SXM	187	4	8	.50	1.20	.31	.88	.093	.120	.225	24	10	58
3/4" # 16 SXM	60	4	8	.92	2.00	.81	1.75	.062	.106	.200	13	6	85
3/4" # 13 SXM	91	4	8	.92	2.00	.75	1.69	.093	.108	.200	13	6	78
3/4" # 9 SXM	205	4	8	.92	2.00	.69	1.56	.140	.161	.300	13	6	67
1-1/2" # 16 SXM	45	4	8	1.33	3.00	1.25	2.75	.062	.115	.220	9	4	89
1-1/2" # 13 SXM	68	4	8	1.33	3.00	1.25	2.62	.093	.116	.220	9	4	86
1-1/2" # 9 SXM	137	4	8	1.33	3.00	1.13	2.50	.140	.155	.280	9	4	75

**Standard (Raised) Expanded Aluminum**

1/2" .051 SXM	27	4	8	.50	1.20	.38	.94	.051	.093	.158	24	10	70
1/2" .081 SXM	44	4	8	.50	1.20	.38	.94	.081	.096	.186	24	10	60
3/4" .051 SXM	17	4	8	.92	2.00	.81	1.75	.051	.109	.200	13	6	90
3/4" .081 (L) SXM	32	4	8	.92	2.00	.78	1.59	.081	.129	.200	13	6	76
3/4" .081 (H) SXM	41	4	8	.92	2.00	.75	1.69	.081	.166	.300	13	6	74
3/4" .125 SXM	65	4	8	.92	2.00	.69	1.69	.125	.170	.305	13	6	66
1-1/2" .081 SXM	22	4	8	1.33	3.00	1.19	2.50	.081	.128	.240	9	4	87
1-1/2" .125 SXM	43	4	8	1.33	3.00	1.19	2.50	.125	.163	.300	9	4	78

**Flattened Expanded Carbon Steel**

Style	Lbs. Per 100 Sq. Ft.	Standard Sheet Size (Feet)		Design Sizes Inches		Opening Size Inches		Approx. Strand Size (Inches)		Overall Thickness (In.)	Approx. No. Diamonds Per Ft.		% Open Area
		Width SWD	Length LWD	SWD	LWD	SWO	LWO	Thickness	Width		SWD	LWD	
1/4" # 20 FXM	83	4	8	.25	1.03	.09	.69	.030	.086	.030	48	12	47
1/4" # 18 FXM	111	4	8	.25	1.03	.09	.69	.040	.086	.040	48	12	40
1/2" # 20 FXM	40	4	8&10	.50	.126	.38	1.00	.029	.070	.029	24	10	72
1/2" # 18 FXM	66	4	8&10	.50	1.26	.28	1.00	.039	.109	.039	24	10	69
1/2" # 16 FXM	82	4	8&10	.50	1.26	.25	1.00	.050	.103	.050	24	10	60
1/2" # 13 FXM	140	4	8&10	.50	1.26	.25	1.00	.070	.122	.070	24	10	57
3/4" # 16 FXM	51	4	8&10	.92	2.10	.75	1.75	.048	.115	.048	13	6	75
3/4" # 14 FXM	63	4	8&10	.92	2.12	.69	1.81	.061	.119	.061	13	6	70
3/4" # 13 FXM	75	4	8&10	.92	2.10	.69	1.78	.070	.119	.070	13	6	73
3/4" # 10 FXM	114	4	8	.92	2.10	.64	1.76	.070	.160	.070	13	6	68
3/4" # 9 (10 ga.) FXM	171	4&5	8&10	.92	2.12	.56	1.69	.120	.164	.120	13	6	63
1" # 16 FXM	41	4	8	1.09	2.56	.88	2.25	.048	.115	.048	12	5	77
1-1/2" # 16 FXM	38	4	8	1.33	3.20	1.06	2.75	.048	.123	.048	9	4	82
1-1/2" # 14 FXM	46	4	8	1.33	3.20	1.06	2.75	.060	.138	.060	9	4	82
1-1/2" # 13 FXM	57	4	8&10	1.33	3.20	1.06	2.75	.070	.138	.070	9	4	80
1-1/2" # 9 (10ga.) FXM	111	4	8&10	1.33	3.20	1.00	2.56	.110	.175	.110	9	4	77

**Flattened Expanded Stainless Steel**

1/2" # 18 FXM	69	4	8	.50	1.25	.31	1.00	.040	.093	.040	24	10	68
1/2" # 16 FXM	86	4	8	.50	1.25	.31	1.00	.050	.093	.050	24	10	60
1/2" # 13 FXM	178	4	8	.50	1.25	.25	1.00	.080	.132	.080	24	10	56
3/4" # 16 FXM	57	4	8	.92	2.10	.75	1.81	.050	.118	.050	13	6	75
3/4" # 13 FXM	87	4	8	.92	2.10	.63	1.75	.070	.120	.070	13	6	74
3/4" # 9 (10 ga.) FXM	195	4	8	.92	2.10	.56	1.69	.119	.160	.119	13	6	64
1-1/2" # 16 FXM	43	4	8	1.33	3.20	1.06	2.75	.050	.124	.050	9	4	83
1-1/2" # 13 FXM	65	4	8	1.33	3.20	1.00	2.63	.079	.124	.079	9	4	79
1-1/2" # 9 (10ga.) FXM	131	4	8	1.33	3.20	0.94	2.63	.119	.165	.119	9	4	76

**Flattened Expanded Aluminum**

1/2" .051 FXM	25	4	8	.50	1.27	.31	1.00	.040	.104	.040	24	10	57
1/2" .081 FXM	41	4	8	.50	1.27	.31	1.00	.060	.105	.060	24	10	57
3/4" .051 FXM	16	4	8	.92	2.12	.75	1.81	.040	.122	.040	13	6	73
3/4" .081 FXM (L)	30	4	8	.92	2.12	.64	1.77	.070	.143	.070	13	6	66
3/4" .081 FXM (H)	38	4	8	.92	2.12	.69	1.75	.070	.181	.070	13	6	63
3/4" .125 FXM	61	4	8	.92	2.12	.63	1.75	.095	.187	.095	13	6	55
1-1/2" .081 FXM	20	4	8	1.33	3.15	1.06	2.75	.055	.143	.055	9	4	75
1-1/2" .125 FXM	40	4	8	1.33	3.15	1.00	2.75	.080	.181	.080	9	4	65

Notes:

All weights are approximate and meet or exceed current Industry Standards.  
Galvanized expanded metal weighs more than non-galvanized material.

Please consult factory for exact weights, flattening limitations or in the event material meeting ASTM Specification F1267 should be required.

**How to order expanded metal grating**

The following information should always be included when placing an expanded metal grating order:

1. Always specify the number of pieces, style and sheet size, as in the following example:  
30 pcs., 5.0# expanded metal grating, 4' x 8'  
*NOTE: The sheet size SWD (short way of diamond) is always specified first and the sheet size LWD (long way of diamond) is specified second, i.e. SWD x LWD. If your expanded metal grating is for a catwalk application, the LWD will typically run the short way of the sheet. This is because a shorter LWD provides greater support over the span of the walkway. Example: 30pcs., 3.0# carbon steel expanded metal grating catwalk, 10'SWD x 3'LWD.*
2. If special sheet sizes are required, state exact sheet size and type of shearing wanted, or dimensional tolerance allowed. Expanded metal grating is normally furnished bond sheared on the first bond over the specified dimension (both SWD and LWD); however, in some cases it can be furnished random sheared to a closer tolerance if required.

Standard tolerances on special sheet sizes are as follows:

- Bond Sheared Sheets -0", +1/2 diamond
- Random Sheared Sheets + - 1/8"

3. Specify the type of metal wanted. Example: Carbon steel, stainless steel, aluminum, etc.
4. If your expanded metal grating requirements involve walkway and platform areas that cannot be specified in simple sheet sizes, contact our Sales Engineer for assistance.

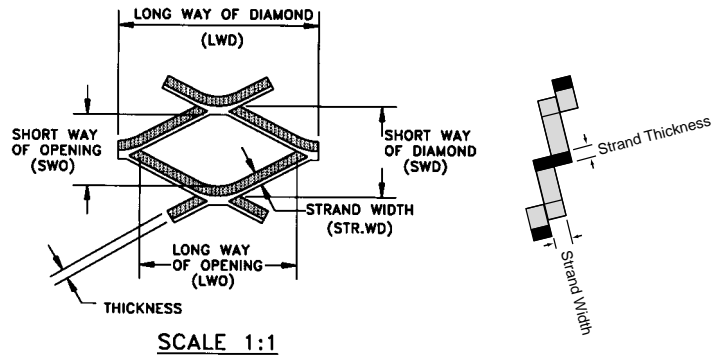

**How to read load table**

The expanded metal grating flooring Load Table is based on the following:

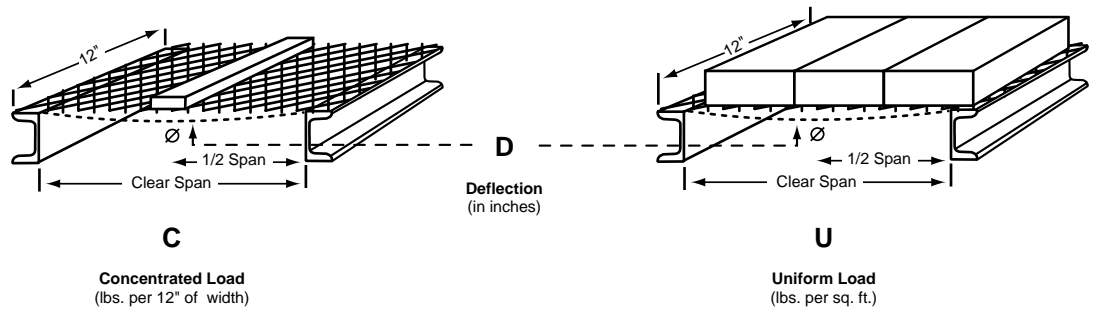

**Clear Span:** The distance between supports, measured from the inside edge of one support to the inside edge of the next support.

**Concentrated Load:** A load distributed over a relatively small area, such as a pedestrian load or portable equipment load. Typical concentrated loads are shown in pounds per foot of grating width, measured perpendicular to the span (i.e. in the SWD direction).

**Deflection:** The deviation in inches from the original plane when a piece of grating is placed under load.

**Uniform Load:** A load uniformly distributed over all of the clear span. Typical uniform loads are shown in pounds per square foot of grating.

Expanded metal is an extraordinarily versatile material—one with thousands of uses. It is most easily classified as either standard or flattened, but can also be grouped according to specific end-uses (for example, filter mesh, industrial mesh, grating and decorative meshes). The major areas of use are for enclosure, protection, manufacturing, construction, support and decoration.



Expanded metal is commonly produced in, but not limited to, carbon steel, aluminum and stainless steel. In sheet form, the strong, rigid, non-raveling open mesh permits free passage of light, sound, heat, air and liquids while preventing unwanted objects (or persons) from entering.

**Expanded metal grating**

Expanded metal grating is a heavy duty expanded metal produced from carbon steel sheet and plate. Expanded metal grating contains no joints or welds, as each sheet is a single piece of sturdy steel.

Pattern shown is actual size:

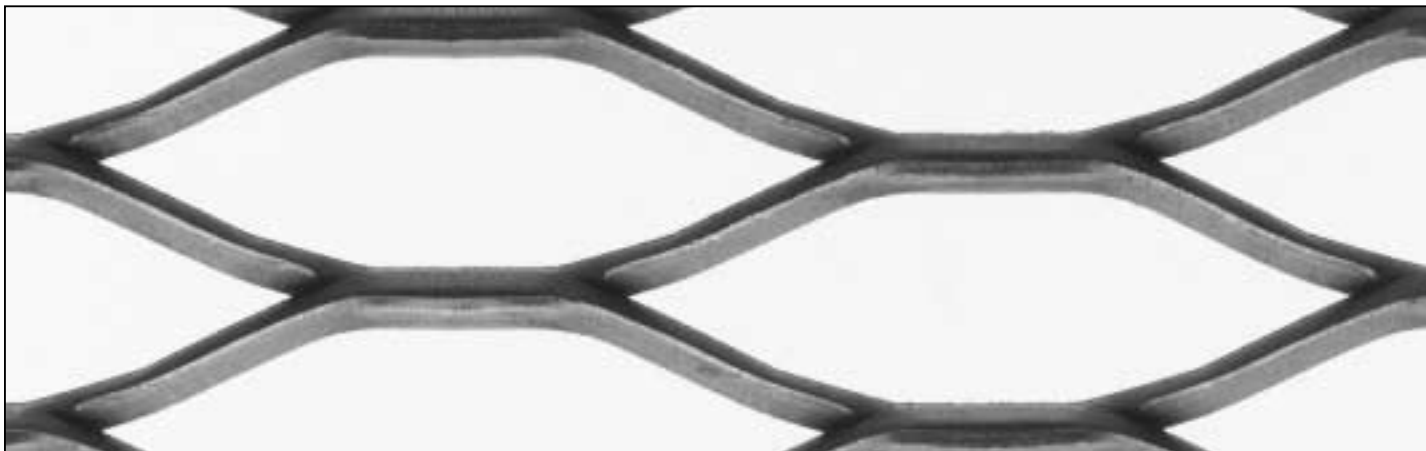

3 lb. Grating

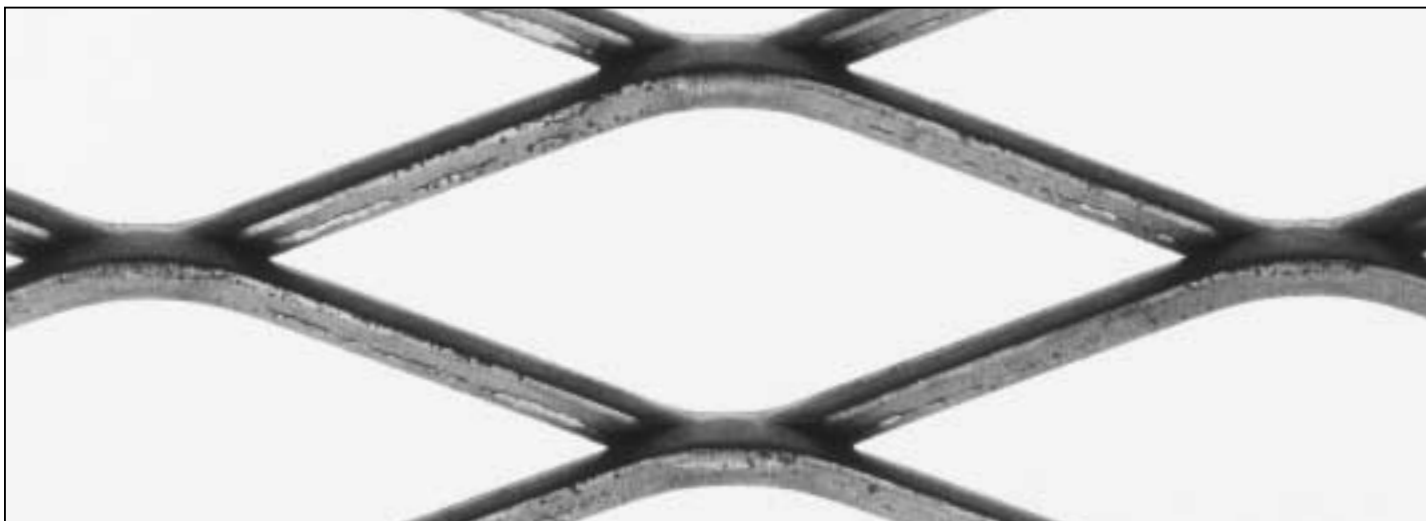

3.14 lb. Grating

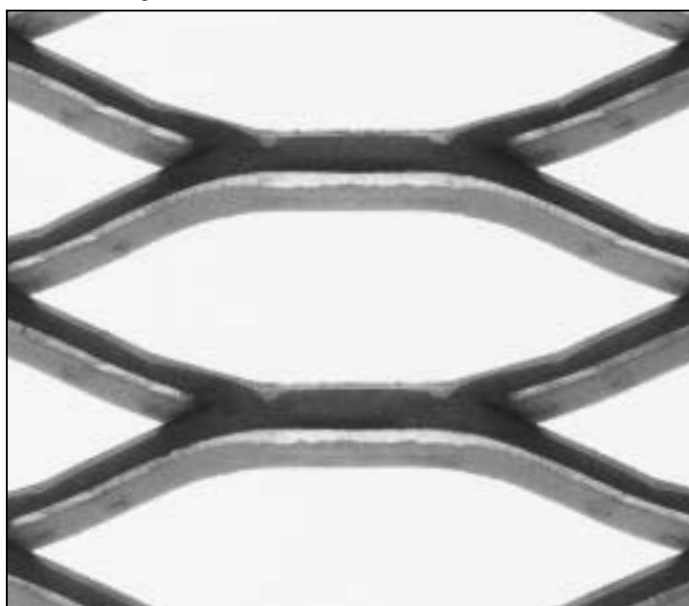

4 lb. Grating

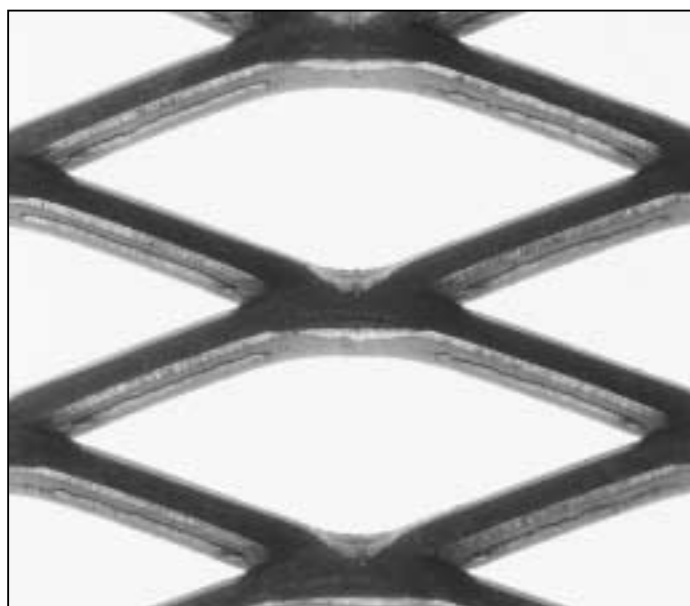

4.27 lb. Grating

# EXPANDED METAL GRATING

Style	Color Code	Lbs. Per 100 Sq. Ft.	Standard Sheet Size (Feet)		Design Size Inches		Opening Size Inches		Approx. Strand Size (Inches)		Overall Thickness (In.)	Approx. No. Diamonds Per Ft.		% Open Area
			Width SWD	Length LWD	SWD	LWD	SWO	LWO	Thickness	Width		SWD	LWD	

## Carbon Steel Standard Grating

3 lb.	White	300	4&6	8&10	1.33	5.33	0.940	3.44	.183	.261	.540	9	2.25	73
3.14 lb.	Orange	314	4&6	8&10	2.00	6.00	1.625	4.88	.250	.308	.656	6	2	74
4 lb.	Yellow	400	4&6	8&10	1.33	5.33	0.940	3.44	.215	.297	.618	9	2.25	65
4.27 lb.	Green	427	4&6	8&10	1.41	4.00	1.000	2.88	.250	.297	.625	8.5	3	58
5 lb.	Blue	500	4&6	8&10	1.33	5.33	0.813	3.38	.250	.327	.655	9	2.25	52
6.25 lb.	Gold	625	4&6	8	1.41	5.33	0.813	3.38	.312	.347	.715	8.5	2.25	55
7 lb.	Red	700	4	8	1.41	5.33	0.813	3.38	.312	.388	.740	8.5	2.25	60

## Aluminum Grating

2 lb.	Plain	200	Inquire		1.33	5.33	.940	3.44	.250	.371	.730	9	2.25	48
-------	-------	-----	---------	--	------	------	------	------	------	------	------	---	------	----

## Stainless Steel Grating

3.3 lb.	Plain	330	Inquire		2.00	6.00	1.625	4.88	.250	.312	.656	6	2	69
4.5 lb.	Plain	450	Inquire		1.41	4.00	1.508	2.88	.250	.300	.625	8.3	3	58

## Carbon Steel Catwalk-Long Length SWD

2 lb.	Plain	200	10	2	1.33	5.33	1.00	3.44	.120	.267	.480	9	2.25	60
3 lb.	White	300	10&12	2,3,4&5	1.33	5.33	0.940	3.44	.183	.261	.500	12.8	3.5	73
3.14 lb.	Orange	314	10	2&3	2.00	6.00	1.625	4.88	.250	.308	.562	7.4	2.5	74
4 lb.	Yellow	400	10	2&3	1.33	5.33	0.940	3.44	.215	.297	.625	12.8	3.5	65
4.27 lb.	Green	427	10	2&3	1.41	4.00	1.000	2.88	.250	.297	.625	12	4.2	58
5 lb.	Blue	500	10	2&3	1.33	5.33	0.813	3.38	.250	.327	.625	14.8	3.6	52

### 3.0 lb. Grating

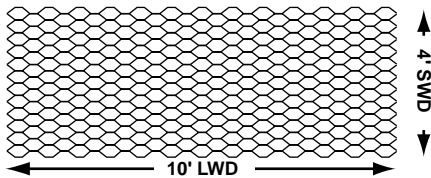

SWD= Short Way of Diamond

LWD= Long Way of Diamond

### 3.0 lb. Grating Catwalk

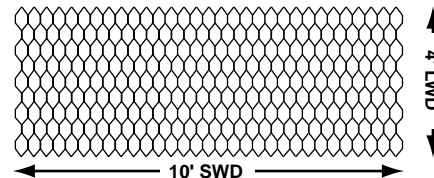

## Expanded Metal Grating Selection Guide

In selecting an appropriate type of grating, the designer decides first on the general characteristics required, such as safety, open area and ease of maintenance. After the basic product is selected, he/she must determine the proper style of grating to satisfy the load and span conditions. The following information will help you select

the proper style of grating for the job:

- Determine the clear span.
- Determine the load condition and the amount of load.
- Select the appropriate grating style from the guide below.

Concentrated Load At Center of Span (Lbs. per Foot of Width)	Clear Span									
	18"	24"	30"	36"	42"	48"	54"	60"	66"	72"
<b>Carbon Steel</b>										
50	3.0 3.14	3.0 3.14	3.0 3.14	3.0 3.14	3.0 3.14	4.0 4.27	5.0 6.25	6.25 7.0	6.25 7.0	7.0
100	3.0 3.14	3.0 3.14	3.0 3.14	3.0 3.14	4.0 4.27	5.0 6.25	7.0			
150	3.0 3.14	3.0 3.14	3.0 3.14	5.0 6.25	5.0 6.25	7.0	7.0			
200	3.0 3.14	3.0 3.14	4.0 4.27	5.0 6.25	6.25 7.0	7.0				
250	3.0 3.14	3.0 3.14	4.0 4.27	6.25 7.00	7.0					
300	3.0 3.14	4.0 4.27	5.0 6.25	7.0						
350	3.0 3.14	4.0 4.27	6.25 7.0	7.0						
400	3.0 3.14	4.0 4.27	6.25 7.0							

Above chart information conforms with Military Specifications MIL-M-17194C (Metals Expanded Steel) and MYL-G 18015 (ships) (grating) and the deflection requirements of Federal Specifications RR-G-661-B.

**Fabrication and Installation Instructions**

We recommend the following:

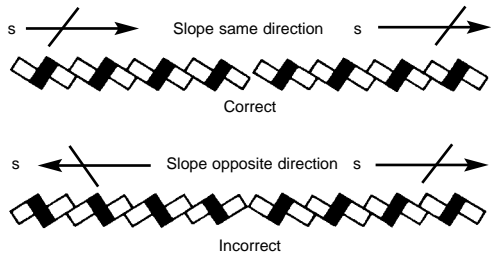

**1. Directions for placing grating.**

The strands of adjoining sheets should slope in the same direction.

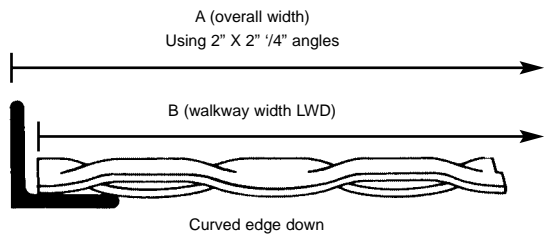

**2. Top and bottom of sheet.**

The face of the sheet with flat straight edged mesh intersections is the top side. The reverse face of the sheet has curved edges at the intersections.

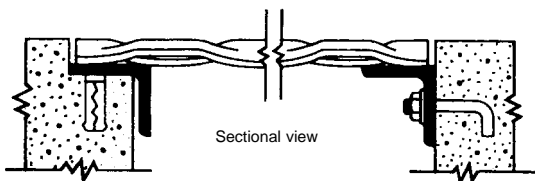

**3. Recessed grating for trenches.**

The ends of the grating should bear on structural supports.

Adjoining (butting or lapped) sheets can be welded together.

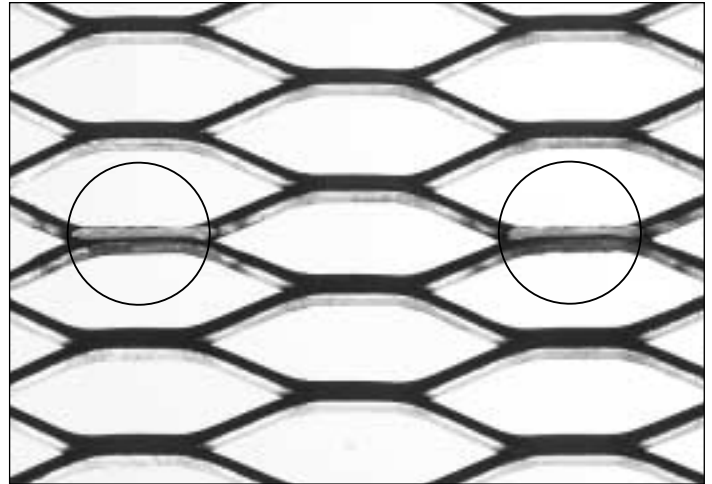

**4. Sheets joined by butt welding.**

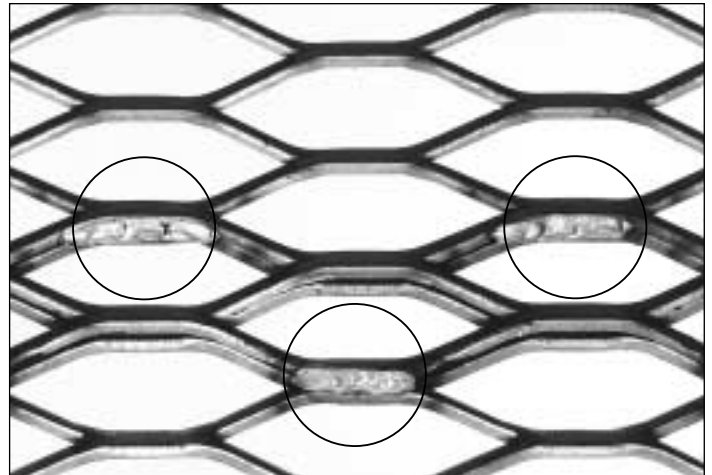

**5. Sheets joined by overlap welding.**

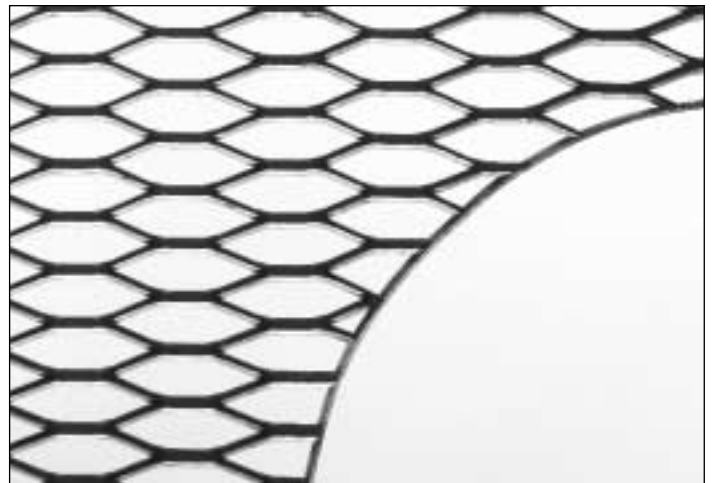

**6. Banding of grating at circular and diagonal cuts.**

It is easy to fabricate expanded metal grating and cut holes for pipes or structural members. All cut-outs should be edged with bar welded at contact points.

Grating is heavy duty expanded metal produced from carbon steel sheet and plate which contains no joints or welds, as each sheet is a single piece of sturdy steel. Lightweight and economical, expanded metal grating is ideal for use wherever a strong, durable, lightweight surface is needed. It is the standard product specified by engineers for use in catwalks, ramps, stairs, platforms, heavy duty shelving, truck-cab safety screens, ship and off-shore rig flooring and in partitions where high security is important.



The high percentage of open area, characteristic of expanded metal grating, allows snow, water and oil to drain off easily, thus maintaining the excellent slip-resistant surface. The same high percentage of open area also allows excellent passage of heat and light, and contributes to walkway cleanliness. Where building maintenance and safety are important considerations, these features are outstanding.



**How to order expanded metal**

The following information should always be included when placing an expanded metal order:

1. Specify the number of pieces wanted.
2. Specify the nominal dimension of the diamond SWD.  
Example: 3/4"
3. Specify the style of the sheet.  
Example: # 18; or if aluminum .081
4. Specify whether standard or flattened.
5. Specify the type of metal wanted.  
Example: carbon steel, stainless steel, aluminum, etc.
6. Specify the size sheet wanted.  
Example: 4' SWD x 8' LWD

**Standard Mesh - Example: 3/4" # 9 SXM**

**Flattened Mesh - Example: 3/4" # 9 FXM**

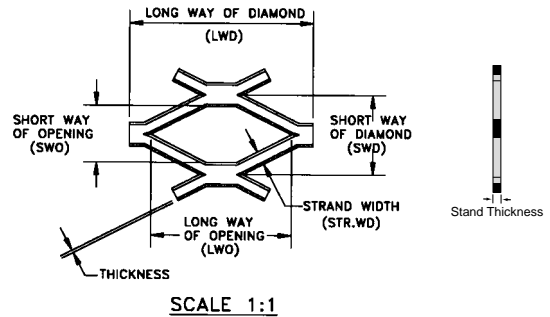
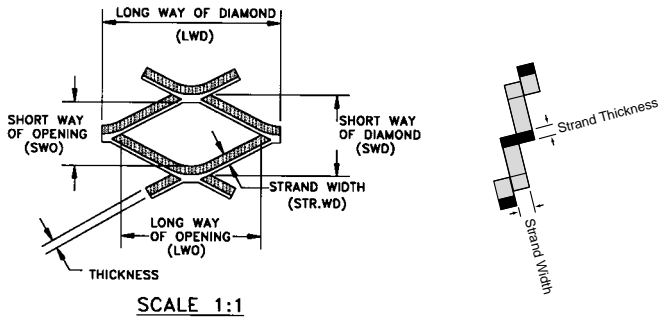

This example illustrates the information necessary for a Steel Service Center to fill your order.  
Example - 100 sheets 3/4" # 9 standard expanded metal carbon steel 4' SWD x 8' LWD.

**Manufacturing tolerances for stock size sheets**

**Sheet Dimensions:**

SWD - 0" + 3/16" per foot of width  
LWD - 0" + 1 diamond

**Out-of-Squareness:**

SWD 1/16" per foot of width  
LWD 1/16" per foot of length (measured with 90 degree angle)

**Thickness:**

+ or - 10% of published thickness

**Camber:**

SWD 1/16" per foot of width  
LWD 1/16" per liner foot (as measured by the greatest distance between the edge of the sheet and a straight-edge placed across the two ends of the sheet)

The above tolerances apply to all stock items listed in our literature.  
FOR SPECIAL SIZES OF EXPANDED METAL PLEASE CONSULT THE PLANT.

**Shearing**

**Side Shearing.** The process of cutting a piece of expanded metal parallel to the long dimension of the diamond.

**Random Side Shearing.**

Side shearing is a cut made parallel to the LWD dimension of the sheet which usually leaves open diamonds. Standard tolerances on the SWD dimension is plus or minus 1/16" when both sides are sheared.

**Bond Side Shearing.** This cut is made along the length of the sheet on the center line of the bond over specified width. In most cases it is not practical to attempt to bond side shear either regular or flattened expanded metal due to camber.

**End Random Shearing.** The process of shearing a piece of expanded metal to a specified length (LWD). This cut normally leaves open diamonds at both ends but accomplishes close tolerance (plus or minus 1/16") when both are sheared.

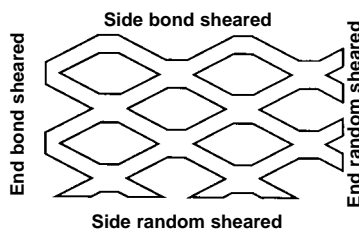

**End Shearing.** The process of cutting a piece of expanded metal parallel to the short way of the diamond.

**End Bond Shearing.** The process of shearing a piece of expanded metal to a specified length (LWD). A plus or minus 1/16" tolerance applies when both ends are sheared. One end is cut on the bond parallel to the SWD, the other end usually has open diamonds. *NOTE: When end bond shearing is requested for both ends the sheet is sheared at the center line of the bond over the specified length with the tolerance of plus or minus 1/2 diamond.*

**Squareness.** When all four sides of a sheet of expanded metal are sheared, the maximum tolerance will be plus or minus 1/16" per foot of width.

*NOTE: Bond shearing provides closed diamonds that facilitate handling and safety but frequently result in higher cost and always require greater dimensional tolerance. Random shearing is normally less costly except where the scrap ("drop-off") is excessive. Also, random shearing is more difficult to handle and presents a greater safety risk due to the sharp edges left on the open diamond.*

Expanded Metal Grating Load Table

Load in Pounds...Deflection in Inches										
XM-Grating	Load Condition	Clear Span	50 lbs.	100 lbs.	150 lbs.	200 lbs.	250 lbs.	300 lbs.	350 lbs.	400 lbs.
3.0 lb. Carbon Steel	C	25	.067	.134	.201	.268				
		30	.113	.226	.339					
		35	.177	.353						
		40	.261							
	U	25	.082	.163	.245	.326				
		30	.166	.331						
35		.303								
3.14 lb. Carbon Steel	C	25	.055	.109	.164	.219	.273			
		30	.088	.176	.264					
		35	.133	.267						
		40	.193	.386						
	U	25	.064	.128	.191	.255				
		30	.124	.248	.372					
35		.221	.442							
40		.367								
4.0 lb. Carbon Steel	C	25	.031	.063	.094	.125	.156	.188	.219	.250
		30	.052	.104	.156	.208	.260			
		35	.081	.161	.242	.322				
		40	.118	.237	.355					
	45	.167	.333							
		25	.036	.073	.109	.146	.182	.219	.255	
U	30	.073	.146	.219	.292					
	35	.132	.265	.397						
	40	.223	.445							
	45	.353								
4.27 lb. Carbon Steel	C	25	.030	.060	.090	.121	.161	.181	.211	.241
		30	.051	.102	.153	.205	.256	.307		
		35	.080	.161	.241	.321				
		40	.119	.238	.357					
	45	.169	.337							
		25	.036	.071	.107	.142	.178	.213	.249	.285
U	30	.073	.145	.218	.290	.363				
	35	.133	.266	.399						
	40	.226	.451							
	45	.360								
5.0 lb. Carbon Steel	C	30	.048	.096	.144	.192	.240	.288		
		35	.076	.152	.228	.303				
		40	.113	.226	.339					
		45	.161	.321						
	50	.220	.440							
		30	.069	.138	.207	.275	.344			
U	35	.127	.254	.382						
	40	.217	.433							
	45	.346								
	30	.032	.064	.096	.128	.161	.193	.225	.257	
C	35	.050	.100	.150	.200	.250	.300			
	40	.073	.147	.220	.294					
	50	.141	.282							
	60	.242	.483							
U	30	.048	.095	.143	.190	.238	.285	.333		
	35	.086	.173	.259	.346					
	40	.146	.292							
	50	.351								
6.25 lb. Carbon Steel	C	30	.031	.062	.093	.124	.154	.185	.216	.247
		35	.047	.093	.140	.186	.223	.280	.374	
		50	.126	.252	.378	.503				
		60	.212	.425						
	70	.332								
		30	.045	.089	.134	.178	.223	.267	.312	
U	35	.079	.158	.237	.316					
	50	.308	.615							

Deflection values indicated by shading are larger than the maximum recommended (1/4") for normal pedestrian comfort but may be safely exceeded at the discretion of the engineer.

**MINI-MESH AND FILTER MESH:**

This expanded metal product is produced of very light gauge metal with small openings. This flame-resistant, rust-resistant material is easy to handle, facilitating assembly by possessing a high degree of flexibility and resistance. Mini-Mesh and Filter Mesh products are often shipped in narrow coils, offering nearly 100% utilization.

Expanded Metal Mini-Mesh and Filter Mesh products have many automotive and industrial uses, such as



automotive air filters, air conditioning units, air filtration systems, agricultural machinery, construction machinery, among others.



**INDUSTRIAL MESH:**

This is the family of products, available in standard sheet sizes (4', 5' and 6' x 8'), offered for general use



purposes. With a mesh range of 1/4" to 1-1/2" and gauges ranging from 20 through 6, industrial mesh expanded metal is that used for maintenance, repair, security enclosures, refuse baskets, display shelving, fencing, agricultural equipment, outdoor furniture, utility trailers, and much, much more.

**DECORATIVE MESH:**

This is the group of expanded metal products that

are often chosen by designers and architects for their beauty and striking appearance combined with the many features of other products listed above.

Products classified as expanded metal decorative mesh include Steel Door Guard, DecoGuard and Big-D.

**Steel Door Guard** is a very rigid, steel sheet comprised of very small diamond-shaped

openings that is an ideal product for use in doors as added security against unwanted intrusion. Steel Door Guard is both durable and economical, far surpassing traditional, fragile wire and plastic mesh insect screenings.

**DecoGuard** combines attractive design with the strength of steel to form an elegantly stylish perimeter intruder prevention system. Available in 8 distinct designs, DecoGuard is rigid and is made from a single piece of 1/8" steel that will never ravel or come apart. DecoGuard can be used anywhere where intrusion prevention is a must, such as in window coverings, fences, gates, and more.

**Big-D** is constructed of 3/8" steel plate. It's 6"x 12" diamond-shaped openings allow for maximum air flow and visibility while being the optimum choice for home or office perimeter or entrance intruder protection at a competitive price.



**Products:**

**EXPANDED METAL** is sheet simultaneously slit and stretched into a rigid, open mesh. It is readily available in carbon steel. Aluminum, stainless steel and galvanized steel can also be supplied.

**FLATTENED EXPANDED METAL** is manufactured by processing regular expanded metal in a rolling mill. This rolling reduces the thickness of the sheet and provides a smooth flat surface.

**EXPANDED METAL GRATING** is sheet or plate expanded into a structural open grating ideal for catwalk and platform applications.

**DECORATIVE EXPANDED METAL** is manufactured with unique shaped openings which possess great appeal for architects and designers.

**REFUSE BASKETS** - We produce several types of light weight expanded metal refuse baskets. Catalogs are available.

**MINI-MESH EXPANDED METAL** is manufactured from light gauge metals with small openings and is ideally suited for use in grilles and antennas.

**SQUARE-MESH** - Expanded metal produced with a near equal strand width and strand thickness and a relatively square opening. This results in a symmetrical pattern which provides excellent reflective qualities for use in radar screens and antennas.

**ANTI - GLARE MESH** - Refers to a special group of products used in highway median strips to lessen objectionable headlight glare from oncoming cars.

**STAIR TREADS** - Expanded metal grating stair treads are fabricated using grating, angles and bars. They are shipped ready for installation.

**ACCESSORIES** - Framing items can be made available from manufacturing sources. These same items can usually be procured locally at lesser cost.



**MINE ROOF SHEETING** - A light weight material easily placed and held by conventional bolts to mine roofs. This product serves to protect miners from falling material.

**BARRIER MESH** - This represents several flattened expanded metals used in drywall and plaster ceilings and walls as a security barrier to prevent penetration or access from room to room.

**CONCRETE REINFORCING** - There are several expanded metal products designed specifically for use in many concrete applications, particularly in bank vaults and other very high security construction applications. These are used to provide construction cost savings and superior insurance premium savings. Catalogs, installation, recommendations and complete design support are available.

**Descriptive Terminology:**

**BOND** - The point where adjacent strands intersect. The bond is always twice the width of the strand.

**CSF** - Price and weight of expanded metal are quoted as CSF hundred square feet.

**CAMBER** - A slight bow which can occur during manufacturing and results in an out-of-square condition.

**DEBURRING** - Most expanded metal products are processed through rotary steel brushes to remove burrs and rough edges. Exceptions: those products which are too light and might be distorted and grating.

**DIAMOND OR OPENING** - This is the description of the open area formed by strands and bonds. Normally the open area is diamond shaped.

**DISTRIBUTION** - Expanded metal products are readily available from inventory maintained by your local Steel Service Center.

**FABRICATION** - Some fabrication services can be provided by the manufacturer. Quotations will be furnished promptly when drawings are submitted.

**FINISHING** - Limited finishing can be accomplished at manufacturing plants. This includes annealing, hot dip galvanizing and prime coating. Special finishing such as anodizing, enameling, and plastic coating can be arranged for by contacting your Steel Service Center.

**FXM** - Commonly used abbreviation for Flattened Expanded Metal.

**LWD OR LWO** - Long way of diamond or long way of opening is the dimension measured across the sheet in a direction parallel to the largest dimension of the diamond.

**LEVELING** - All expanded metal products except grating are leveled after having been expanded.

**MESH** - This is the nominal distance from the mid-point of one bond to the mid-point of the next bond measured across the SWD. Mesh is expressed in inches.

**OPENING SIZE** - The area enclosed by bonds and strands.

**OVERALL THICKNESS** - This is the finished thickness and often determines the selection of framing members.

**PERCENT OF OPEN AREA** - These important relative percentages are used by designers to calculate the degree with which light or air can pass through a piece of expanded metal.

**PITCH** - The measurement from a point on one diamond to the same point on an adjacent diamond.

**SHEET SIZE** - While expanded metal can be manufactured in many varying sheet sizes, practical limitations are such that it is wise to select sheet sizes shown in the catalog. Availability can be determined by contacting your Steel Service Center.

**SQUARENESS** - Products are square within manufacturing tolerances. Should squareness be critical, sheets can be square sheared.

**STRAND** - The single metal strip which forms the border of the diamond, or opening. Strand width is the amount of material advanced for expanding as differed from strand thickness, which is the thickness of metal from which the expanded metal is produced.

**STYLE** - It is the approximate gauge or thickness of metal from which expanded metal is made. Usually, but not always, this conforms to manufacturer's standard gauges. Style is expressed by a number. Grating is expressed in pounds per square foot.

**SWD OR SWO** - Short way of diamond, or short way of opening, is the dimension measured across the sheet in a direction parallel to the smallest dimension of the diamond.

**XM** - Widely used abbreviation for Expanded Metal.

**NEW METALS, INC.**

5823 Northgate, Suite 2032

Laredo, TX 78041-2697

Toll Free 1-888-NEW-METALS (1-888-639-6382)

Fax 210-729-1185

<http://www.newmetals.com>

Printed in U.S.A.

5m/7-00